

**SHINI EUROPE**



**Conveyor belts**

# Conveyor belts

## Description:

Plastigo conveyor belts are modern devices used in many different processing sectors as well as in various industries.

As an important element of automation and optimization of the technological process, the conveyor belts are available in many configurations adapted to various production profiles and different Customers' needs.

Plastigo conveyor belts are price attractive for sectors of production using a conveyor transport.

## Advantages:

- stable and solid construction,
- efficient configuration system,
- flexible adjustment to conditions around the machine,
- quick installation and easy maintenance,
- ability to create consistent transport routes cooperating with each other,
- ability to achieve high speed with low drive power,
- ability to set the speed of belt,
- ability to fit the Customer's needs,
- comprehensive usage,
- safe usage,
- silent work.

## Standard models:

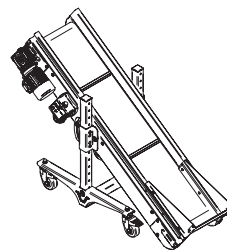

**CLL**

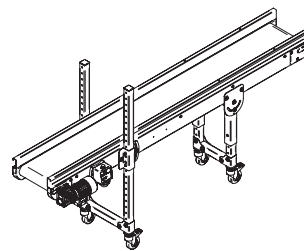

**PNLL**

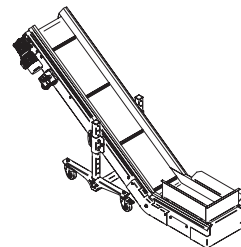

**CBL**

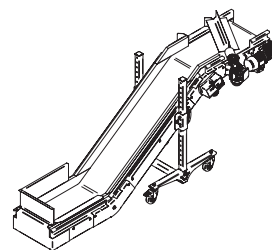

**CBDL**

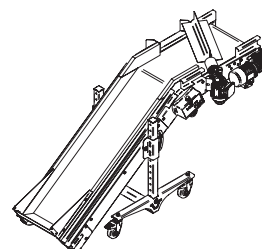

**SVL**

# Features

## Steel or aluminum frame

Solid and robust aluminum, steel or stainless-steel frame provides stability of the machine and allows quick and easy installation of the separator. It is equipped with stainless-steel infeed chute at load end.

## Modularity

Conveyor belts allow to create consistent, cooperating with each other production lines. Devices are made as universal modules what allow quick installation, easy maintenance and modification when changing a conception of setting aside the details.

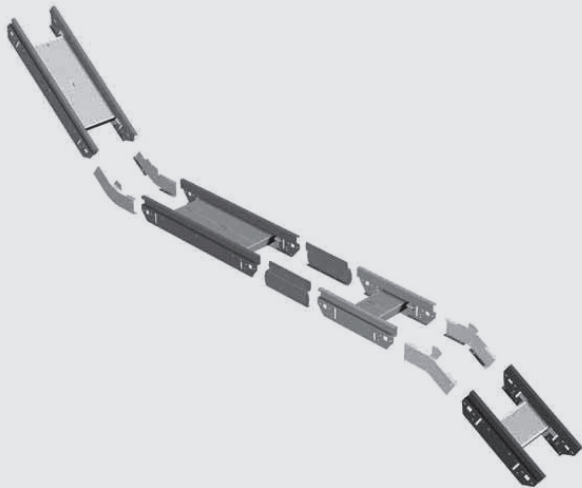

## Telescopic legs

Fitted under the transporter or by its edge, they allow to regulate height and angle of the machine quickly and easily. Polyurethane swivel castors 100mm diameter with a brake allow moving and setting the machine on the right spot.

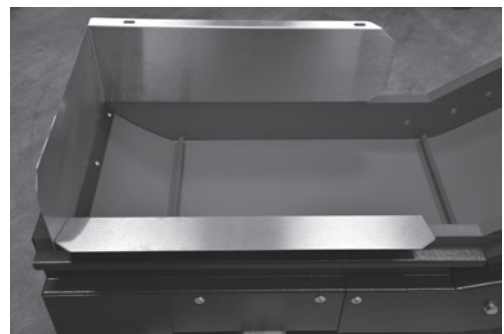
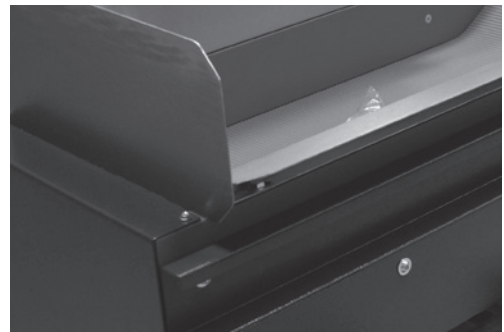

## Solid and sealed edges

The belt of the conveyor adhere closely to the side walls, prevents from jamming small details at the edges. The parallel side frames ensure centering of the belt and prevents from loosing the moulders.

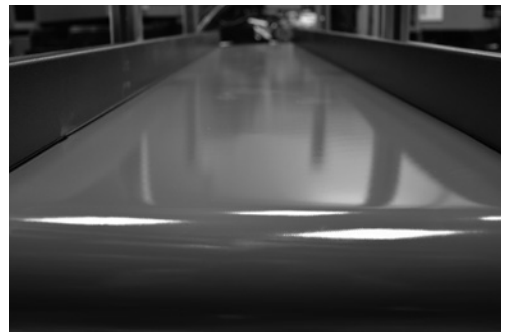

## Side walls

The side walls of CB, CBD and SV conveyor belts are made out of antifriction material (polyzene). They are directly fitted on the conveyor's belt prevents from getting small parts underneath the belt or jamming them by the edges.

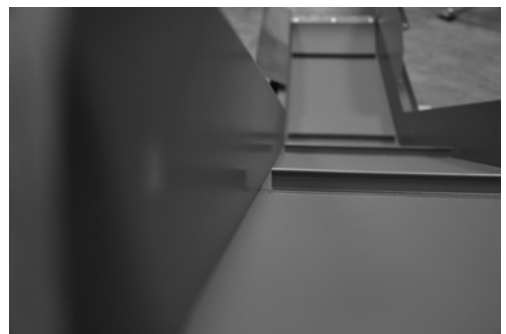

## High torque gear motor

Steel or polyurethane drive shaft increases stiffness of the belt and provides effective power transmission. Driven via motor of 0,22 kW mounted directly on the drive shaft and self-centering supports.

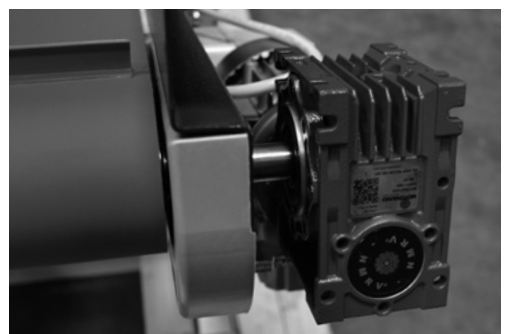

## Non-slip, triple-layer, high resistance belt

PVC belt (resistant up to 60°C) or PU belt (resistant up to 120°C) made of triple-layer, provides high transverse stiffness of the belt.

## Control system using the inverter

Control box with a built-in inverter allows a smooth regulation of belt's speed, work based on signal provided by any external device, choice between continuous and discontinuous operation and change of belt direction.



## Teflon in structural elements

Teflon is characterized by non-inflammability, outstanding chemical resistance and it is physiologically neutral (suitable for food contact). It has good sliding properties, wide range of work temperatures, high resistance to UV radiation and good electrical insulating properties. It guarantees a low coefficient of friction.

## Powder coating

Powder coating is used in protective, anti-corrosion and decorative purpose. It guarantees a smooth surface, without fractures, damp patches or bubbles. It protects from high temperature and chemical factors.

## Hydraulic support stand (CBL, CBDL)

Allows quick and easy adjustment of height and tilt angle of the conveyor belt with a support of the hydraulic ram. What is more, the stand is equipped with polyurethane swivel castors 100mm diameter with brake facility what allows easy moving of the conveyor belt.

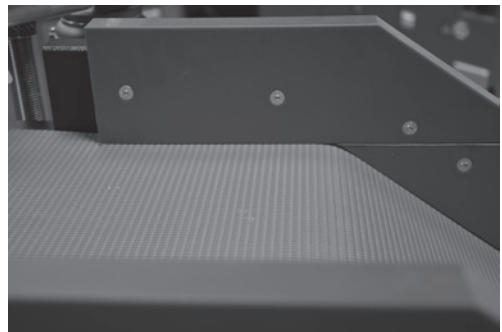
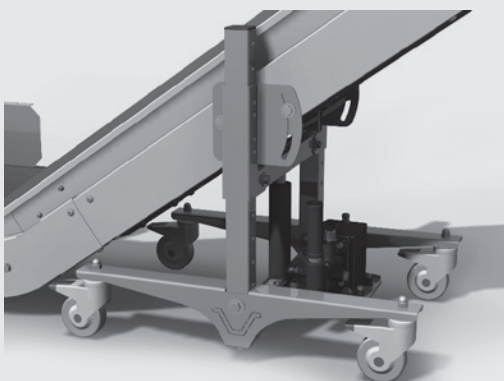

## Standard features

- framework in painted steel ral 7016
- mounted on telescopic support legs
- flat blue PVC belt with flights h 20 mm, pitch 500 mm
- sidewalls h 75 mm
- three sided infeed chute
- fixed speed 4 mt/min
- three phase motor / gearbox kw 0.25
- electronical switch with clean contact receipt 400 V/3ph/50 Hz

## Variations according to the needs

- non slip blue PVC belt
- flat blue PVC belt
- flat blue PVC belt with flights h 30 mm, pitch 500 mm
- fixed speed 6 mt/min

## Options

- speed 1.4 Mt/min (gearbox, ratio 1/240)
- steel 430 output chute
- special colour
- special voltage (single phase not available) or UL/CSA
- connector phoenix for clean contact
- variable speed (see page 17)
- control boxes (see page 18)
- paddle and roll separators (see page 15)

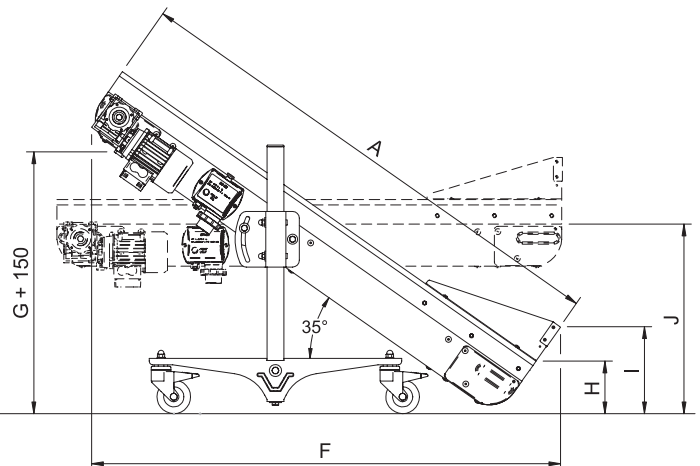
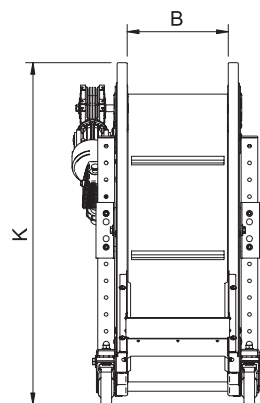
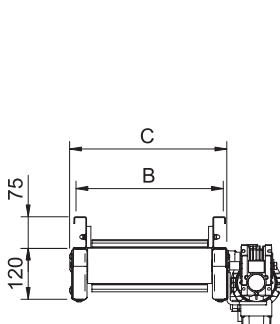
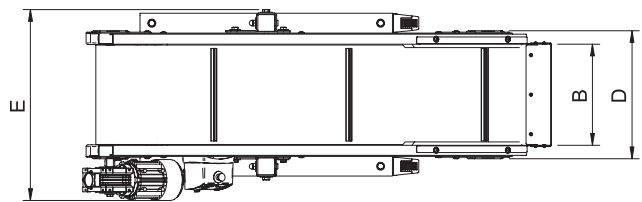
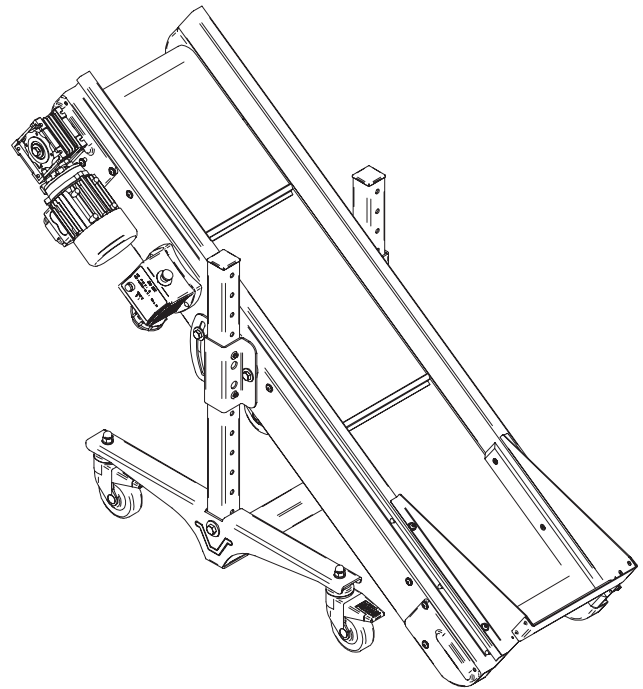

Model	A	B	C	D	E	F	G	H	I	J	K	Kg
CLL/1	1500	220	286	300	500	1395	780	155	260	565	1020	65
CLL/2	1500	300	366	380	580	1395	780	155	260	565	1020	70
CLL/3	1500	400	466	480	680	1395	780	155	260	565	1020	75
CLL/4	1500	500	566	580	780	1395	780	155	260	565	1020	80
CLL/5	2000	400	466	480	680	1805	1070	160	265	715	1310	90
CLL/6	2000	500	566	580	780	1805	1070	160	265	715	1310	95

## Standard features

- framework in painted steel ral 7016
- adjustable height from belt level to ground min. 460 mm max. 1260 mm
- adjustable angle from 0 to 25°
- flat blue PVC belt
- sidewalls h 75 mm (or without sidewalls)
- fixed speed 4 mt/min, 6 mt/min
- three phase motor / gearbox kW 0.25
- electronical switch with clean contact receipt 400 V/3ph/50 Hz

## Options

- adjustable height from belt level to ground min. 460 mm - max. 2060 mm
- motorgearbox underneath the conveyor with chain drive system
- speed 1.4 mt/min (gearbox r 1/240)
- steel 430 three sided infeed chute open at 33° - for all models
- special colour
- special voltage (single phase not available) or UL/CSA
- steel 430 output chute
- connector phoenix for clean contact
- variable speed (see page 17)
- control boxes (see page 18)
- paddle and roll separators (see page 15)

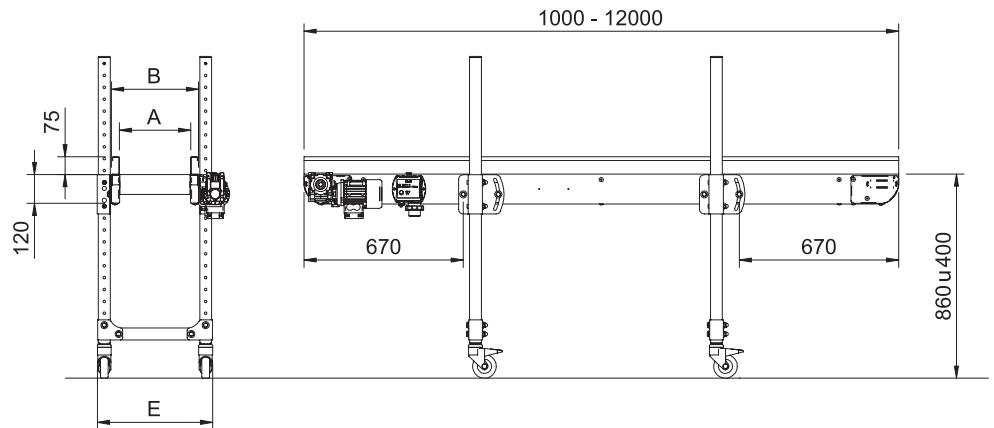
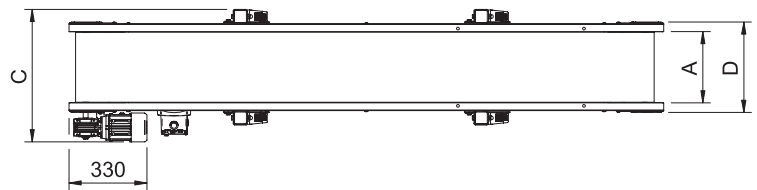
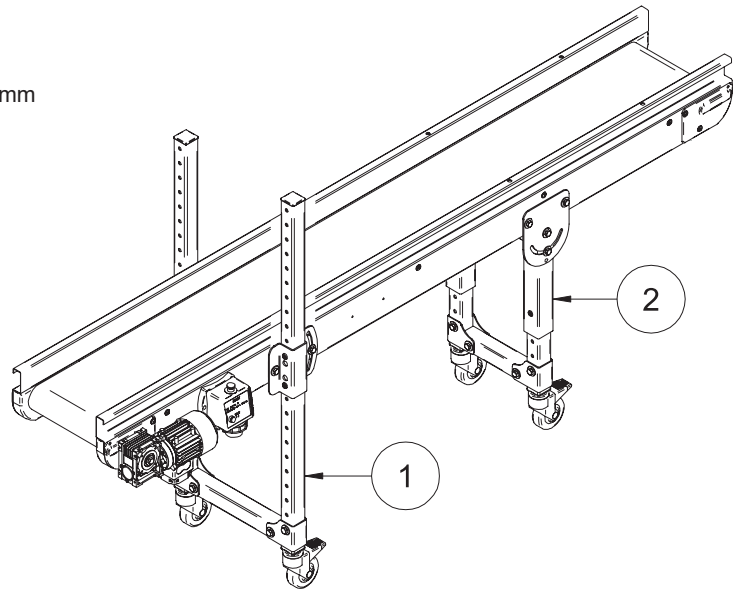

Model	A	B	C	D	E
PNLL/1	220	286	480	300	405
PNLL/2	300	366	560	380	485
PNLL/3	400	466	660	480	585
PNLL/4	500	566	760	580	685
PNLL/5	600	666	860	680	785
PNLL/6	800	866	1060	880	985
PNLL/7	1000	1066	1260	1080	1185
PNLL/8	1200	1266	1460	1280	1385
PNLL/9	1400	1466	1660	1480	1585
PNLL/10	1600	1666	1860	1680	1785



## Standard features

- framework in painted steel ral 7016
- mounted on central telescopic support legs
- flat blue polyurethane belt with flights h 20 mm, pitch 500 mm
- blue antifriction material (polyzene) sidewalls h 95 mm
- reversible two sided infeed chute at loading area with side inlet chute
- fixed speed 4 mt/min
- three phase motor / gearbox kW 0.25
- electronical switch with clean contact receipt 400 V/3ph/50 Hz

## Variations according to the needs

- flat blue polyurethane belt with flights h 30 mm, pitch 500 mm
- non-slip blue PVC belt
- fixed speed 6 mt/min

## Options

- three sided infeed chute open at 33° - for all models
- speed 1.4 Mt/min (gearbox, ratio 1/240)
- steel 430 output chute
- special colour
- special voltage (single phase not available) or UL/CSA
- connector phoenix for clean contact
- variable speed (see page 17)
- control boxes (see page 18)
- single roll separator (see page 15)

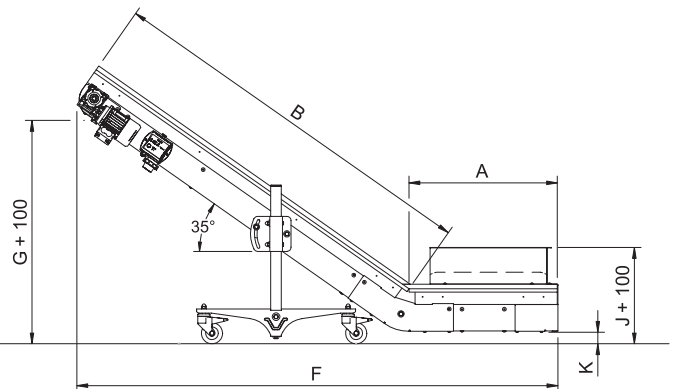
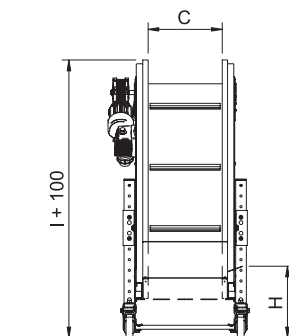
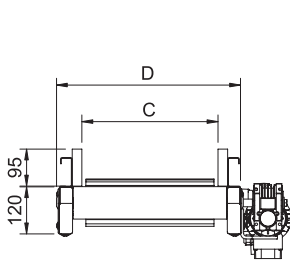
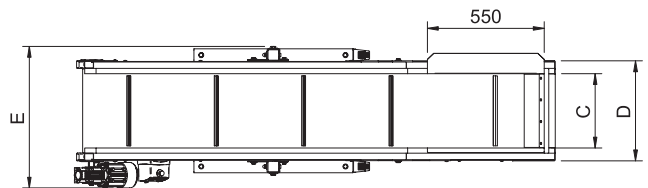
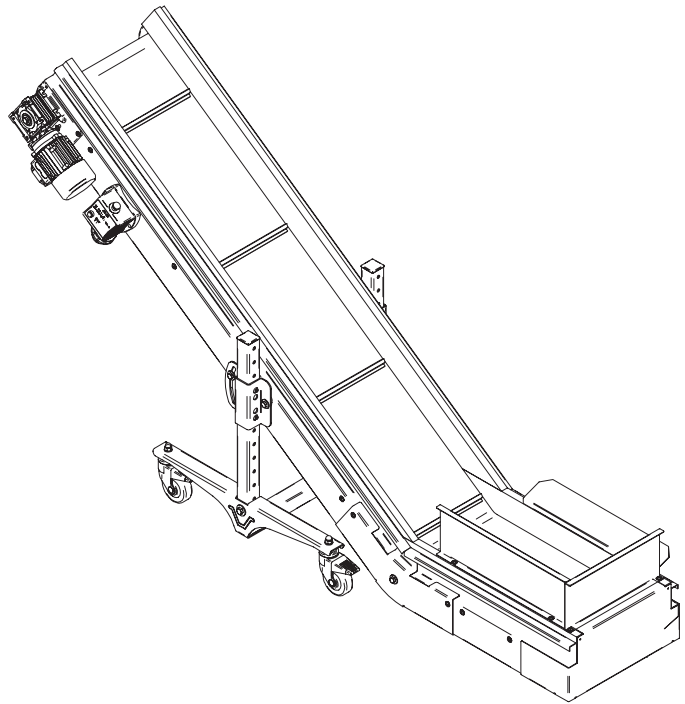

Model	A	B	C	D	E	F	G	H	I	J	K	Kg
CBL/1	700	1300	250	375	570	1860	810	380	1060	500	95	95
CBL/2	700	1300	350	475	670	1860	810	380	1060	500	95	100
CBL/3	700	1300	450	575	770	1860	810	380	1060	500	95	110
CBL/4	700	1800	250	375	570	2270	1055	340	1310	455	55	105
CBL/5	700	1800	350	475	670	2270	1055	340	1310	455	55	115
CBL/6	700	1800	450	575	770	2270	1055	340	1310	455	55	125



## Standard features

- framework in painted steel ral 7016
- equipped with paddle separator
- mounted on central telescopic support legs
- non-slip blue PVC belt
- blue antifriction material (polyzene) sidewalls h 95 mm
- reversible two sided infeed chute at loading area with side inlet chute
- fixed speed 4 mt/min
- three phase motor / gearbox kw 0.25
- electronical switch with clean contact receipt 400 V/3ph/50 Hz

## Variations according to the needs

- flat blue polyurethane belt with flights h 8x8 mm, pitch 500 mm
- flat blue polyurethane belt with flights h 30 mm, pitch 500 mm
- fixed speed 6 mt/min

## Options

- conveyor without paddle separator but pre-set
- paddle separator at opposite side
- three sided infeed chute open at 33° - for all models
- speed 1.4 Mt/min (gearbox, ratio 1/240)
- steel 430 output chute
- special colour
- special voltage (single phase not available) or UL/CSA
- connector phoenix for clean contact
- variable speed (see page 17)
- control boxes (see page 18)
- single roll separator (see page 15)

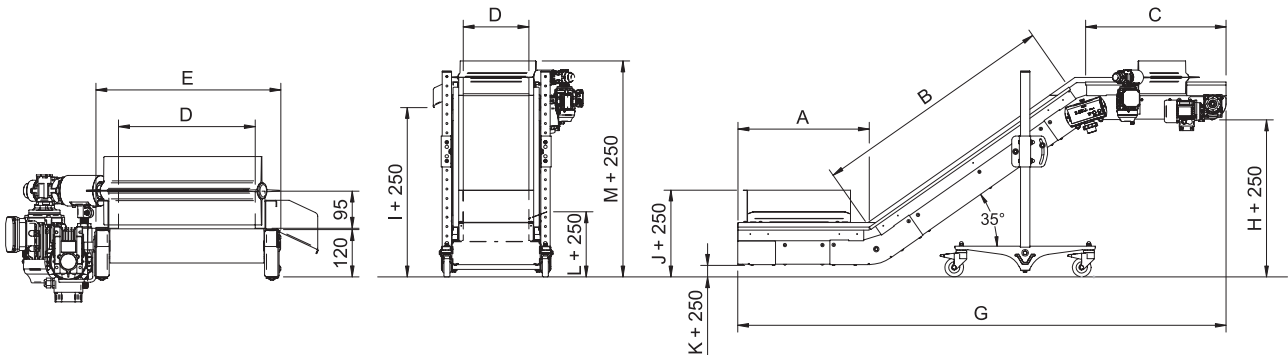
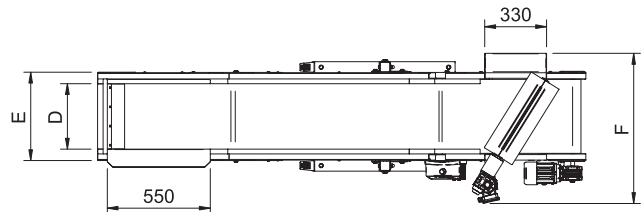
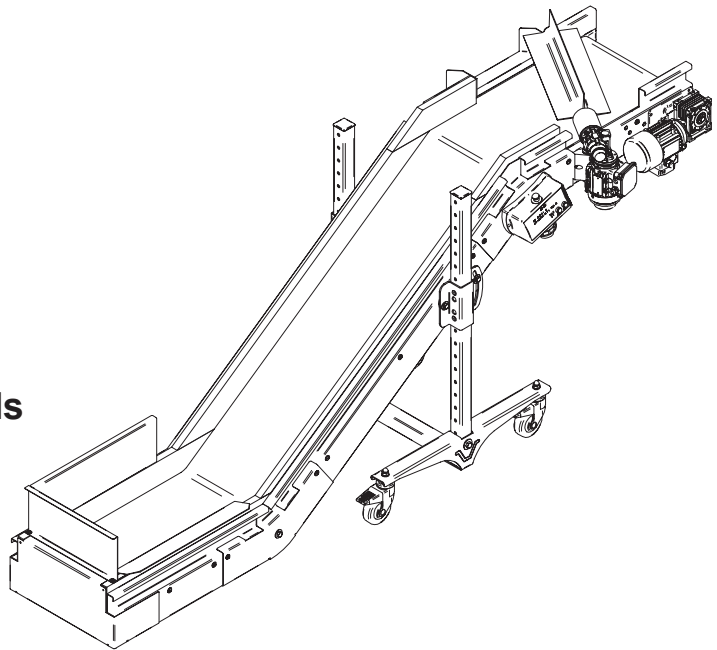

Model	A	B	C	D	E	F	G	H	I	J	K	L	M	Kg
CBDL/7	700	1300	750	250	375	700	2605	835	900	460	60	345	1150	125
CBDL/8	700	1300	750	350	475	800	2605	835	900	460	60	345	1150	140
CBDL/9	700	1300	750	450	575	900	2605	835	900	460	60	345	1150	150
CBDL/10	700	1800	750	250	375	700	3015	1080	1145	415	15	300	1390	140
CBDL/11	700	1800	750	350	475	800	3015	1080	1145	415	15	300	1390	150
CBDL/12	700	1800	750	450	575	900	3015	1080	1145	415	15	300	1390	165

## Standard features

- framework in painted steel ral 7016
- equipped with paddle separator
- mounted on telescopic support legs
- non-slip blue PVC belt
- blue antifriction material (polizene) sidewalls h 95 mm
- three sided infeed chute
- fixed speed 4 mt/min
- three phase motor / gearbox kW 0.25
- electronical switch with clean contact receipt 400 V/3ph/50 Hz

## Variations according to the needs

- flat blue polyurethane belt with flights h 8x8 mm, pitch 500 mm
- flat blue polyurethane belt with flights h 20 mm, pitch 500 mm
- flat blue polyurethane belt with flights h 50 mm, pitch 500 mm
- fixed speed 6 mt/min

## Options

- conveyor without paddle separator but pre-set for its application
- paddle separator at opposite side
- steel AISI 430 output chute
- speed 1.4 mt/min (gearbox ratio 1/240)
- special colour
- special voltage (single phase not available) or UL/CSA
- connector phoenix for clean contact
- variable speed (see page 17)
- control boxes (see page 18)
- single roll separator model sar (see page 15)

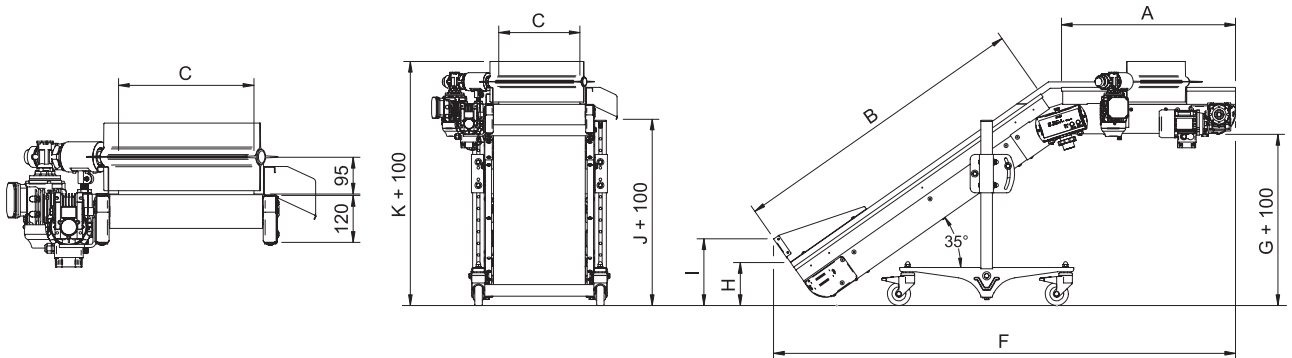
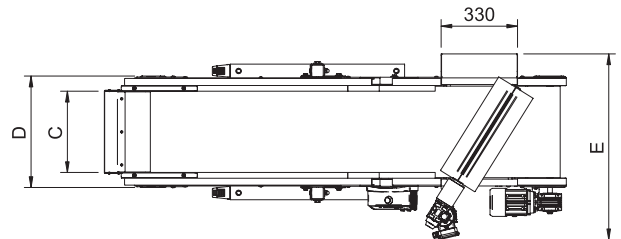
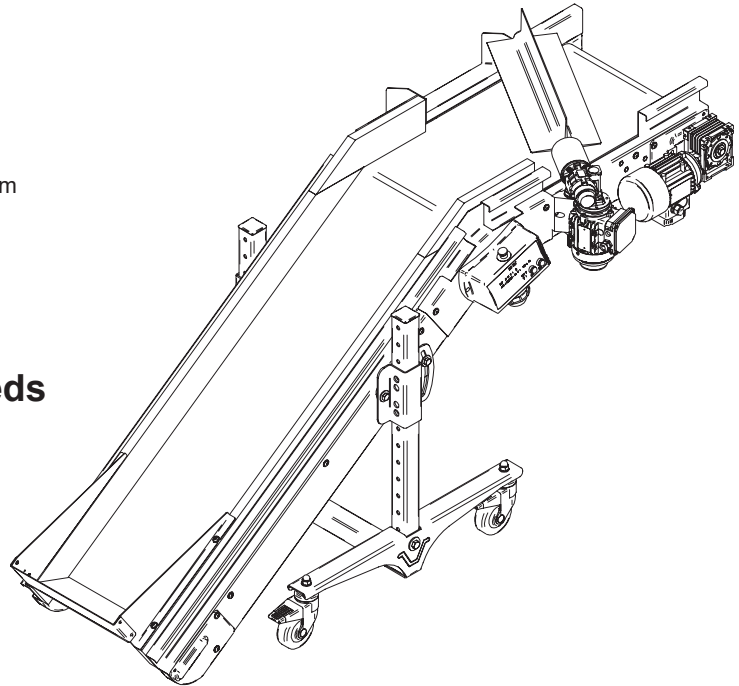

Model	A	B	C	D	E	F	G	H	I	J	K	Kg
SVL/1	750	1300	250	380	700	1990	740	185	290	800	1050	100
SVL/2	750	1300	350	480	800	1990	740	185	290	800	1050	110
SVL/3	750	1300	450	580	900	1990	740	185	290	800	1050	120

## Standard features

- completely made in stainless steel AISI 304
- top belt, for VRA, is PU blue flat with flights h 50 mm, pitch 150 mm
- bottom belt, for VRA and VRB, is PU blue flat with flights h 50 mm, pitch 500 mm
- the support frame is equipped with:
  - a draining device for the overflow
  - a tap for the complete discharge of the water
  - pre - set for the application of the cooling coil
- mechanical speed variator from 0.5 to 2.8 mt/min (on VRA model waterbath included on the top conveyor only)
- electronical switch with clean contact receipt 400 V/3ph/50 Hz

## Options

- cooling coil (to be connected to a chiller)
- pump spray system complete with 4 pipes for floating parts

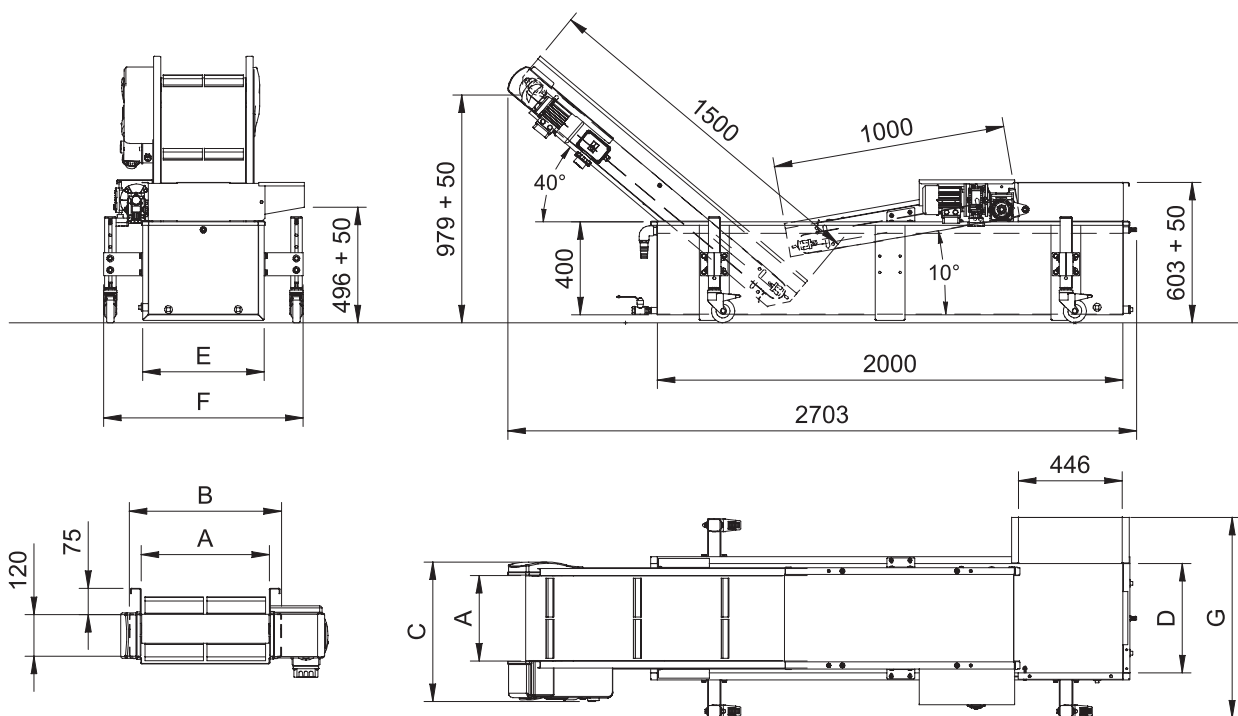

Model	A	B	C	D	E	F	G	Kg
VRA/1	400	466	630	500	550	890	900	200
VRA/2	500	566	730	600	650	990	1000	220

## Standard features

- completely made in stainless steel AISI 304
- bottom belt, for VRA and VRB, is PU blue flat with flights h 50 mm, pitch 500 mm
- the support frame is equipped with:
  - a draining device for the overflow
  - a tap for the complete discharge of the water
  - pre - set for the application of the cooling coil
- mechanical speed variator from 0.5 to 2.8 mt/min
- electronic switch with clean contact receipt 400 V/3ph/50 Hz

## Options

- cooling coil (to be connected to a chiller)
- pump spray system complete with 4 pipes for floating parts

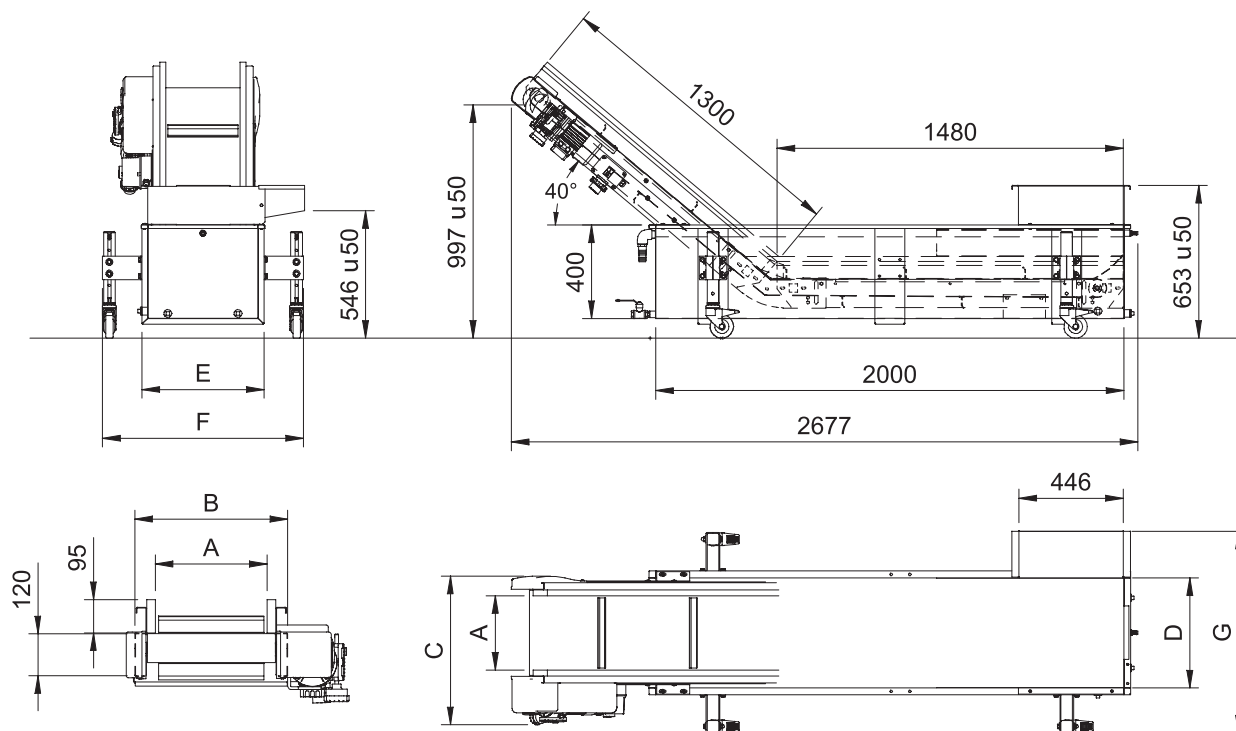

Model	A	B	C	D	E	F	G	Kg
VRB/1	350	466	665	500	550	890	900	200
VRB/2	450	566	765	600	650	990	1000	220

## Standard features

- mounted on telescopic support legs which allow both height and tilt adjustment
- separation section made of stainless steel tubes 30 mm diameter with a pitch that can be easily adjusted
- output chute manufactured in perspex
- stainless steel underneath opening to discharge products directly onto the box
- adjustable sidewalls
- electrical switch with clean contact receipt 400 V/3ph/50 Hz

## Options:

- „lexan” polycarbonate cover over the separation section
- connector phoenix for clean contact

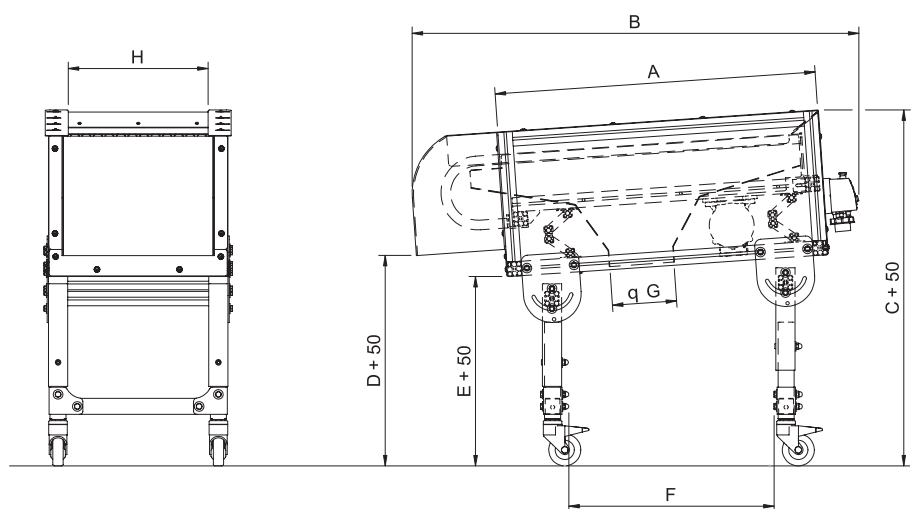
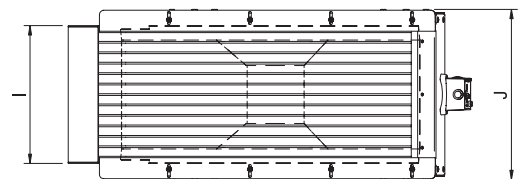
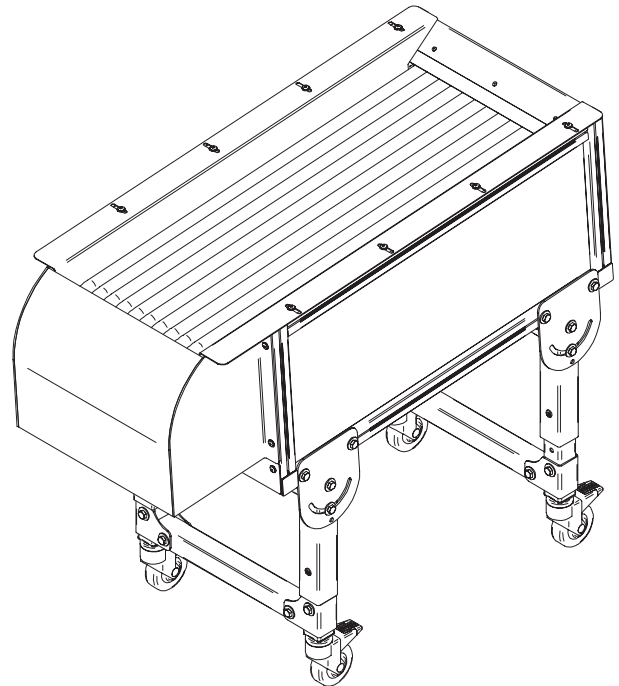

Model	A	B	C	D	E	F	G	H	I	J	Kg
SAV	1000	1400	1110	655	590	640	200	435	475	590	120

## Standard features

- mounted on telescopic support legs which allow both height and tilt adjustment
- separation section made of plastic pipes with an automatic adjustable gap from 4 to 58 mm, thanks to a chain transmission system
- infeed and output chute manufactured in stainless steel
- stainless steel underneath opening to discharge products directly onto the box
- frequency control to adjust the rotation speed

## Optionals

- connector phoenix for clean contact

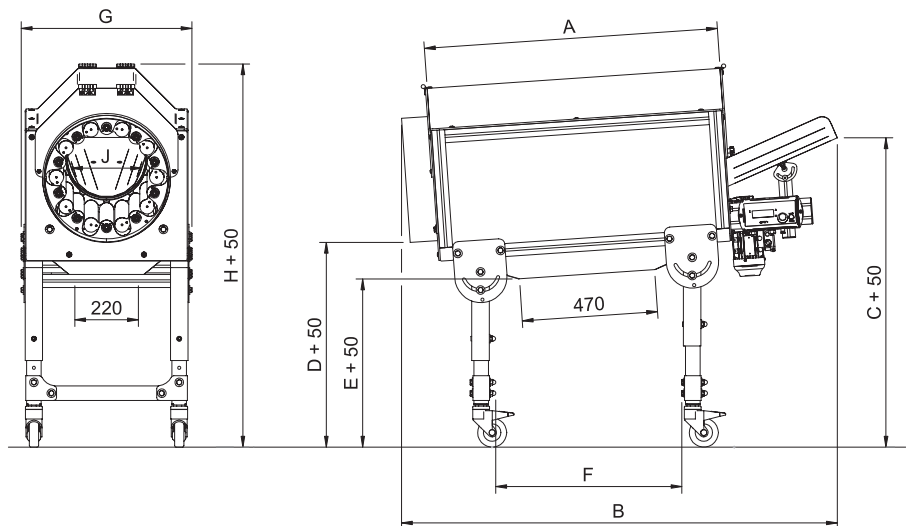
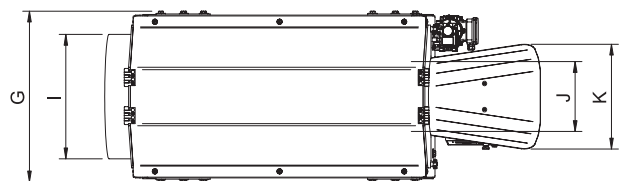
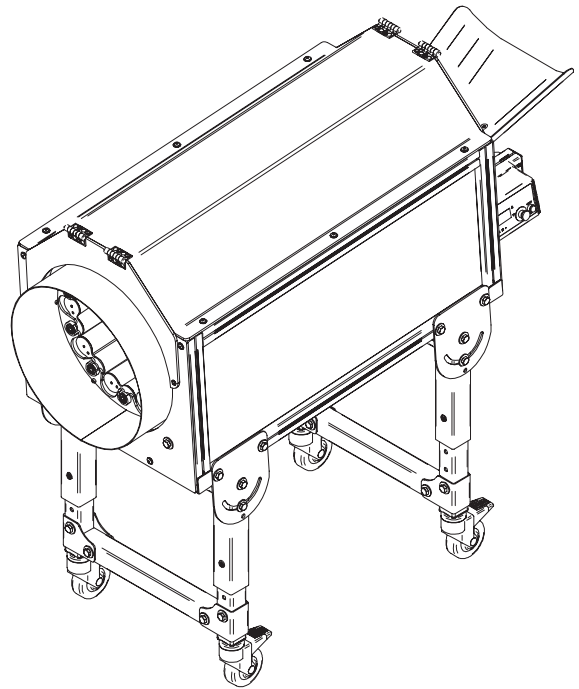

Model	A	B	C	D	E	F	G	H	I	J	K	Kg
SAB	1010	1500	1065	705	580	640	590	1320	430	240	360	105

## SAP

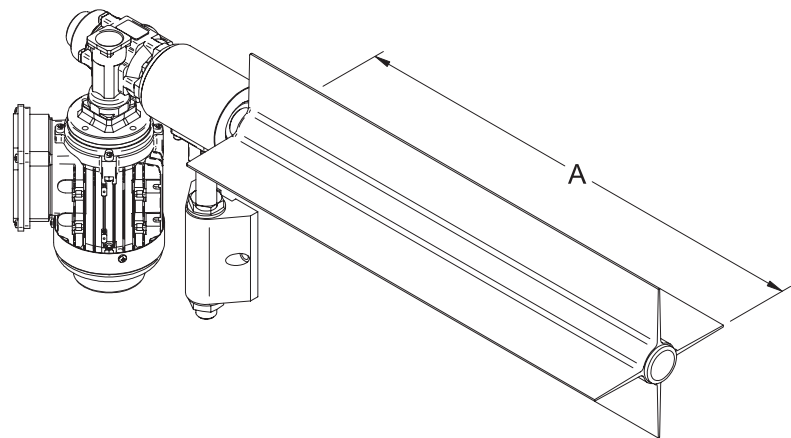
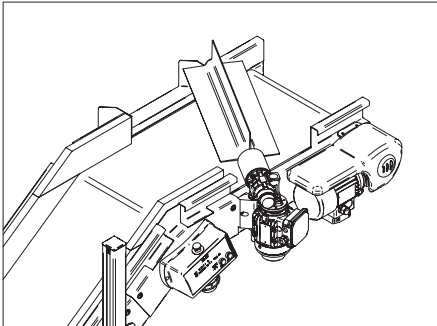

Model	Width	A
SAP/1	220	335
SAP/2	300	385
SAP/3	400	475
SAP/4	500	555
SAP/5	600	645

## SAR

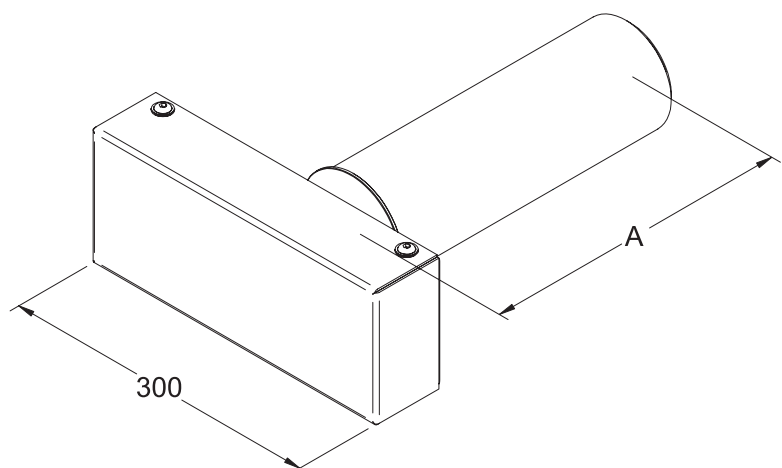
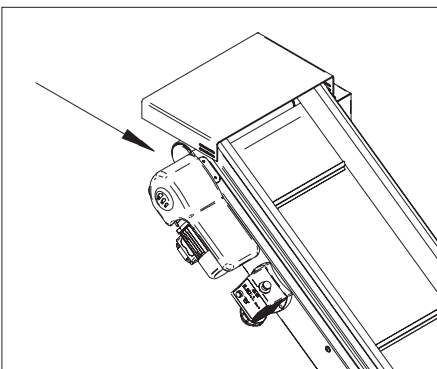

Model	Width	A
SAR/1	220	210
SAR/2	300	290
SAR/3	400	390
SAR/4	500	490

### Optionals

- deflectors (to be fitted on the conveyor)



# SAS / SAS/ST

## SAS

Model	A	B
SAS/1	250	280
SAS/2	350	380
SAS/3	450	480

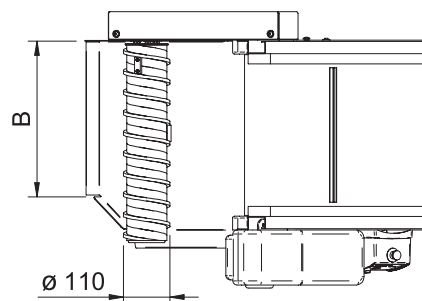
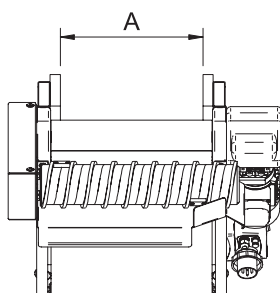
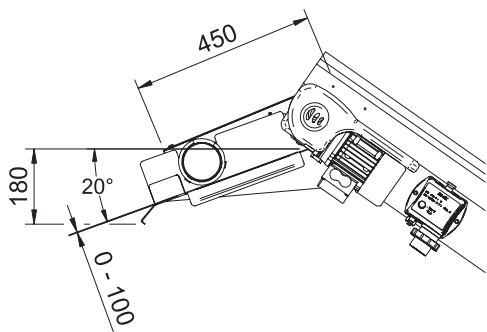
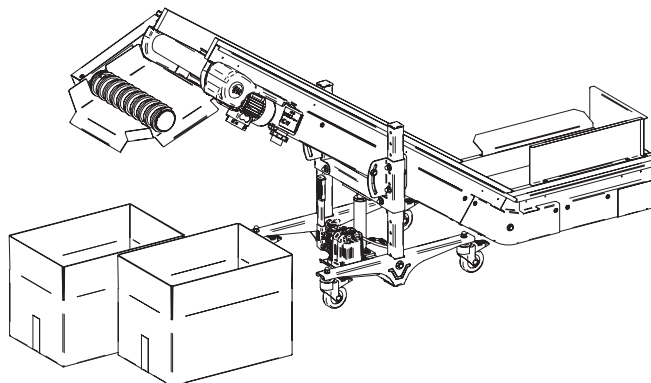

## SAS/ST

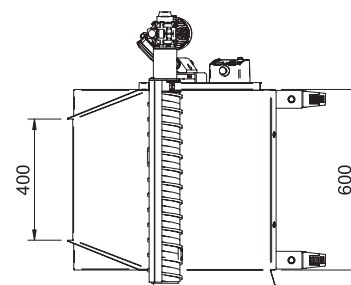
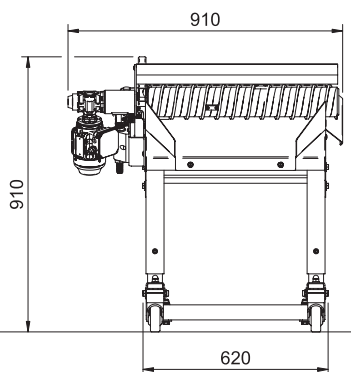
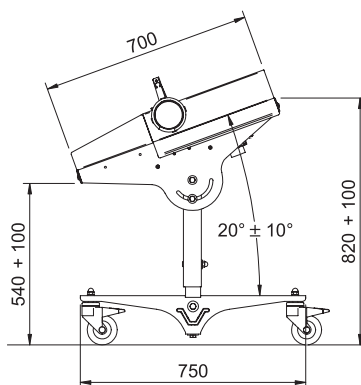
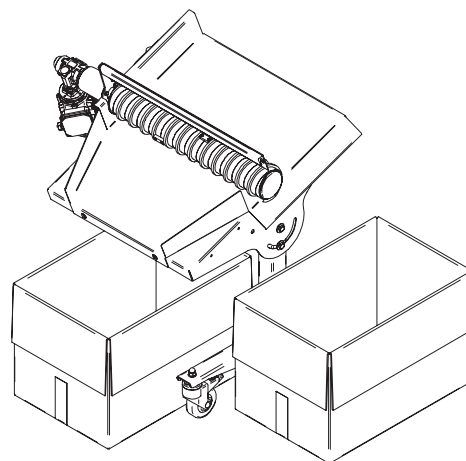

## ADJUSTABLE SPEED WITH INVERTEK

Gearbox ratio i	Fixed speed mt/min	Minimum speed mt/min	Maximum speed mt/min
1:240*	1.4	0.6	1.7
1:80	4.1	1.7	5
1:60	5.5	2.2	6.6
1:40	8.3	3.3	10
1:30	11.1	4.4	13.3
1:20	16.6	6.6	19.9
1:15	22.1	8.8	26.5
1:10	33.2	13.3	39.8

\*Paid extra

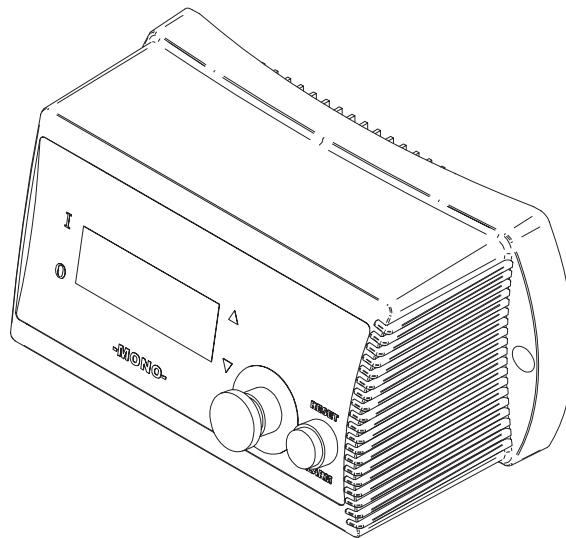

### Optional

Single phase frequency control V. 240 - 60 Hz

- complete with filter in compliance with EMC standards
- on/off external signal control (clean contact)

Connector phoenix for clean contact

## ADJUSTABLE SPEED WITH MECHANICAL VARIATOR

Gearbox ratio i	Fixed speed mt/min	Minimum speed mt/min	Maximum speed mt/min
1:240*	1.4	0.2	0.9
1:80	4.1	0.5	2.8
1:60	5.5	0.7	3.7
1:40	8.3	1.1	5.5
1:30	11.1	1.4	7.4
1:20	16.6	2.1	11.1
1:15	22.1	2.8	14.7
1:10	33.2	4.3	22.1

\*Paid extra

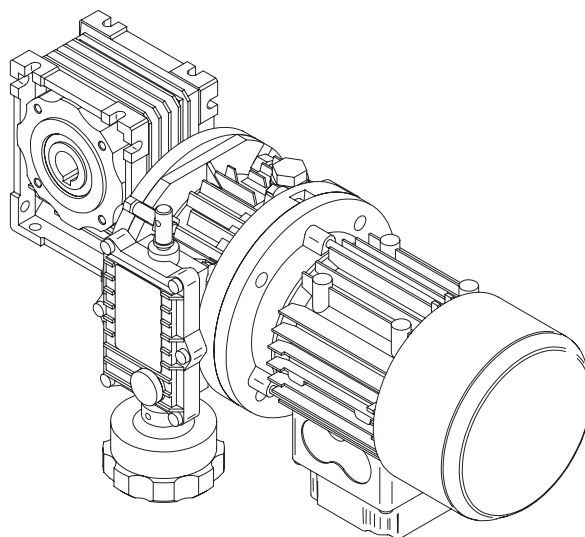

### Optional

Mechanical speed variator 400 V. Three phase – 50 Hz

## 1. CONTROL BOX WITH START/STOP VIA CLEAN CONTACT

### Cod. YQU207-C01.01

- conveyor start after clean contact signal receipt
- button for complete conveyor discharge
- emergency stop button with clean contact signal for robot stop

### Optional

- sensor at conveyor discharge side against products drop
- sensor at conveyor load side for products presence
- visual and audible alarm

## 2. CONTROL BOX WITH MULTIPLE FUNCTIONS

### Cod. YQU251.01

- frequency control for speed adjustment 1,7 – 5 mt/min (or accordingly to gearbox ratio)
- conveyor start after clean contact signal receipt
- indexing timer for working time and indexing timer for stop time
- button for complete conveyor discharge
- emergency stop button with clean contact signal for robot stop

### Optional

- sensor at conveyor discharge side against products drop
- sensor at conveyor load side for products presence
- visual and audible alarm

Note: the above mentioned refer to control boxes with voltage 400 V. – 50 Hz three phase and 0.25 kW

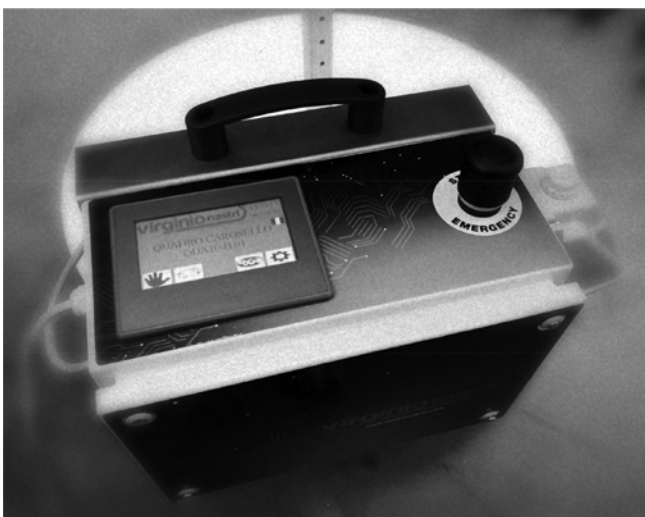

## Standard features

- painted 3 mm thickness rotating plate
- height from the floor to the top of the plate 241 mm
- central shaft with rings  $\varnothing 350$  mm, adjustable from h 725 mm to 1125 mm
- mounting on swivel castors with brake facility
- fixed degrees of rotation: 4 positions for CPS/1, 6 positions for CPS/2, 8 positions for CPS/3
- programmable control box complete with:
  - a cable to receive the signal from the moulding machine's counter, both 24 v. And free (clean) contact
  - a display that shows the total number of mould openings on feeding box
  - delay timer needed by the feeding conveyor for complete discharge
  - stop of feeding conveyor while boxes/bags changing
  - alarm at last box
- rotating speed 5.8 Round/min
- voltage 230 v. Single phase - frequency 50 Hz (loading conveyor connection by voltage 220v three phases)

**NEW  
TOUCH  
PANEL  
CONTROL**

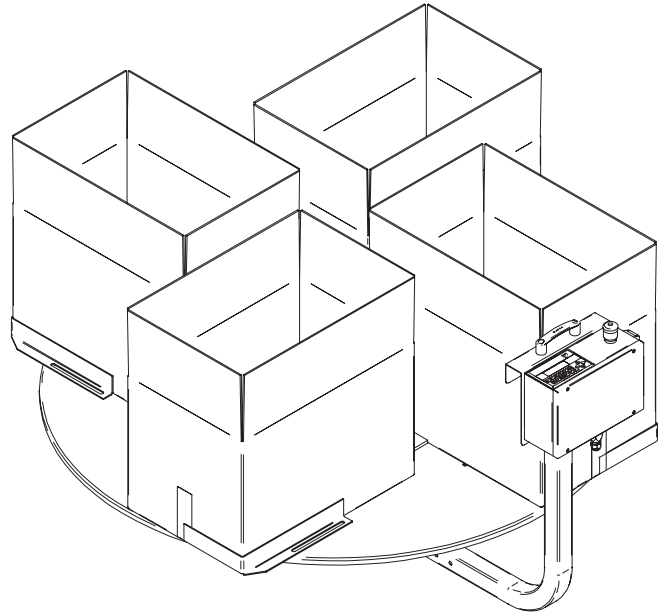

## Options

- additional rings
- carousel without central shaft and rings
- boxes centering star
- brackets for boxes stop

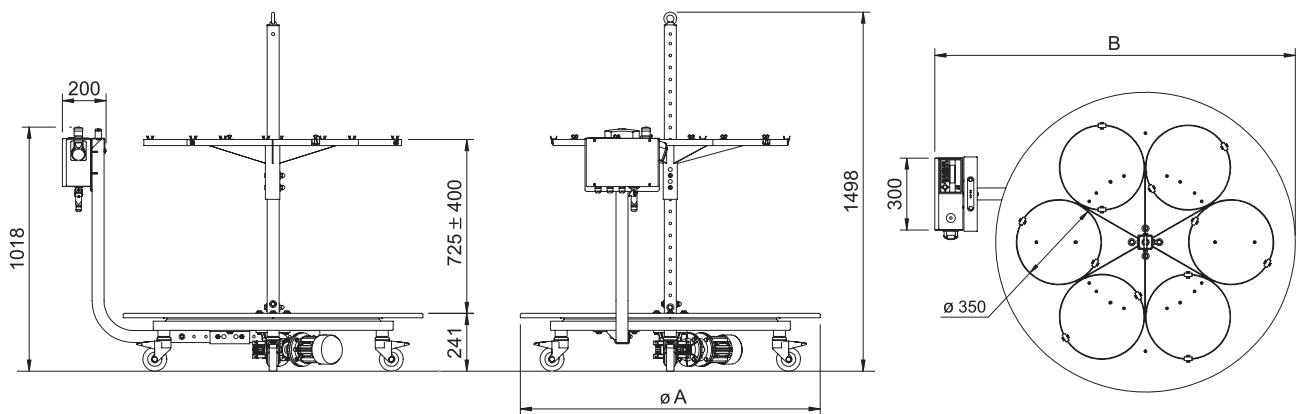

Model	$\varnothing A$	B	Anelli-rings	Kg
CPS/1	1050	1320	4	116
CPS/2	1250	1520	6	128
CPS/3	1450	1720	8	142

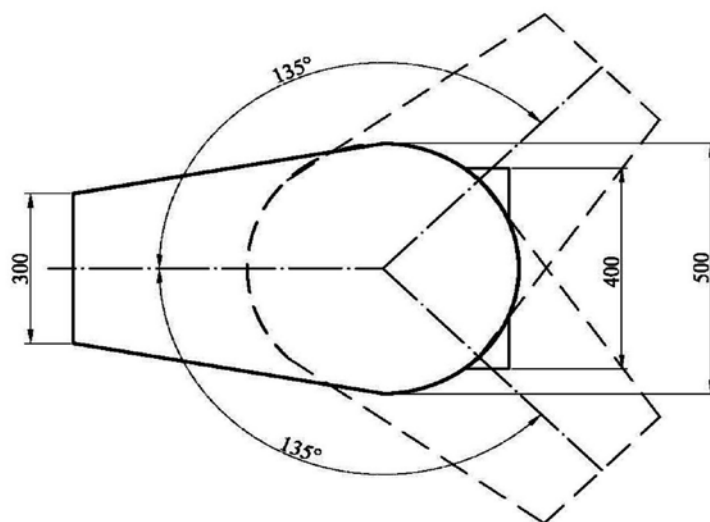
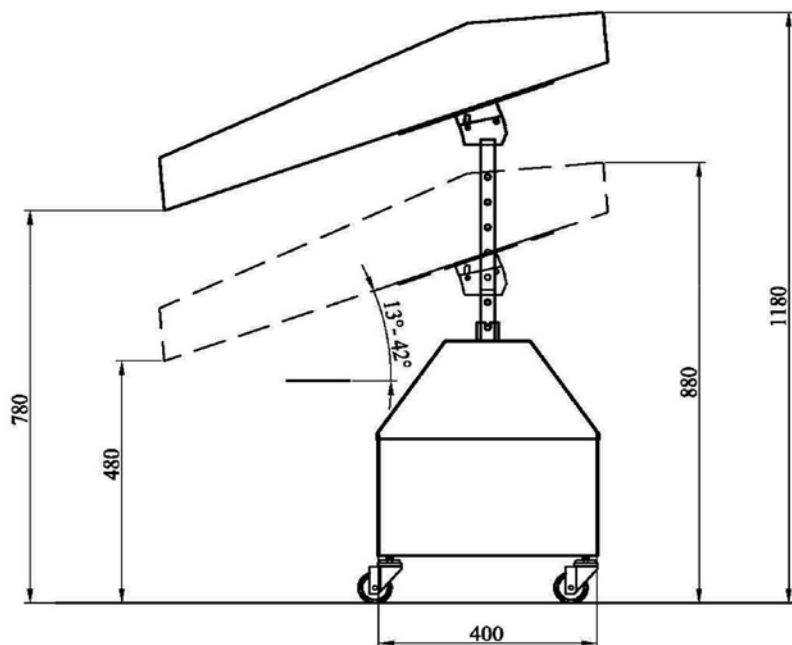

Model	A	B	C	D	E	F	Kg
Duck	300	500	400	880 - 1180	480 - 780	135°	60

**ShiniEurope**

Bór 77/81, 42-202 Częstochowa, Poland

Phone: 0048 34 363 48 78

E-mail: [office@shinieurope.com](mailto:office@shinieurope.com)

[shinieurope.com](http://shinieurope.com)

Copyright by Shini Europe 2021 - PI 01/2021  
Design and content: Marketing Department of AstenGroup.  
Copying of copyrighted material without permission  
of AstenGroup is strictly prohibited.

Information in this catalogue do not constitute trade offer  
in the meaning of the Civil Code. We reserve the right  
to change specification without prior notice.